

Winger Electronics WEQGN02-C2M 3528 PLCC2 SMD LED

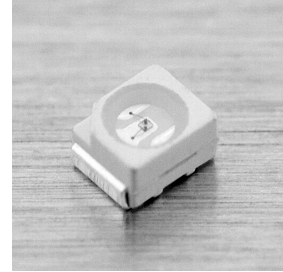

Description

- PLCC2 SMD LED
- Emitting Color: Green

Dimension figure

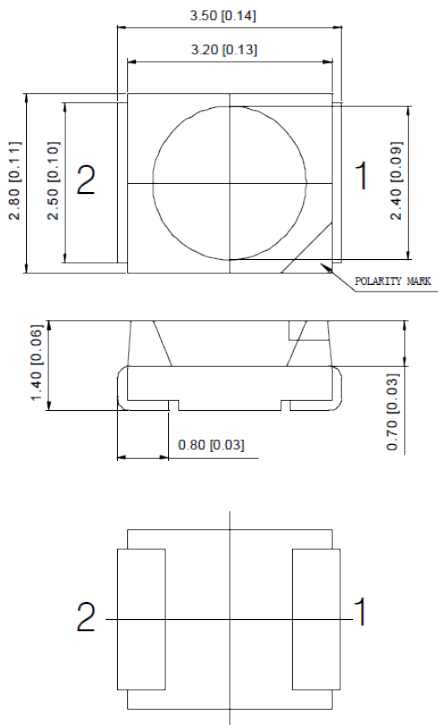

Polarity

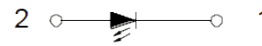

Recommended Soldering Pattern

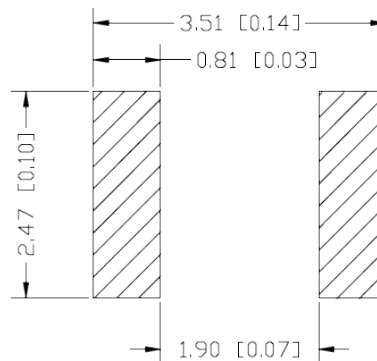

Unit: mm
Tolerances: ± 0.25 mm

Absolute Maximum Ratings

| Item | Symbol | Absolute Maximum Rating | Unit |
|----------------------------|-----------|-------------------------|------|
| Forward Current | I_F | 30 | mA |
| Peak Forward Current * | I_{FP} | 100 | mA |
| Reverse Voltage | V_R | 5 | V |
| Power Dissipation | P_O | 102 | mW |
| Operating Temperature | T_{OPR} | -40 ~ +85 | °C |
| Storage Temperature | T_{stg} | -40 ~ +100 | °C |
| Lead Soldering Temperature | T_{SOL} | Max. 3 sec @ 300 | °C |

* I_{FP} Conditions: 1/10 Duty Cycle, 0.1ms Puls Width

Typical Optical/Electrical Characteristics

| Item | Symbol | Condition | Min. | Typ. | Max. | Unit |
|-----------------------------|--------------|------------|------|------|------|---------|
| Forward Voltage | V_F | $I_F=20mA$ | 2,8 | 3 | 3,4 | V |
| 50% Power Angle | | | - | 120 | - | deg |
| Luminous Intensity | I_V | | 3,1 | 4 | 4,7 | lm |
| Dominant Wavelength | λ_D | | 515 | 520 | 525 | nm |
| Color Temperature | T_C | | - | - | - | K |
| Color Rendering Index | CRI | | - | - | - | Ra |
| Recommended Forward Current | $I_{F(rec)}$ | | - | - | 20 | mA |
| Reverse Current | I_R | $V_R=5V$ | - | - | 10 | μA |

Notes:

1. Absolute maximum ratings $T_a=25^\circ C$
2. Measurement Tolerances of Forward Voltage $\pm 0.1V$
3. Measurement Tolerances of peak wavelength $\pm 2.0nm$
4. Measurement Tolerances of luminous intensity $\pm 15\%$
5. Measurement Tolerances of angle intensity $\pm 15\%$

Typical electrical and optical characteristics

Ambient Temperature vs. Forward Current

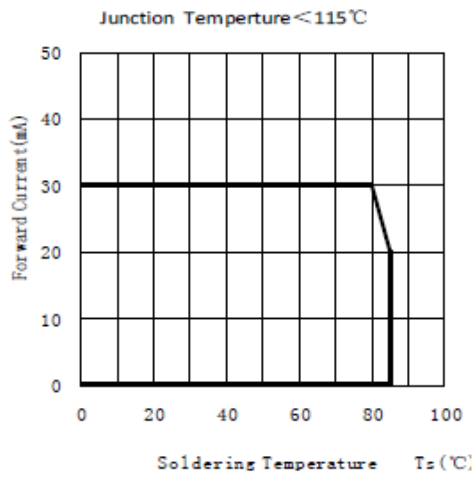

Forward Current VS. Relative Intensity

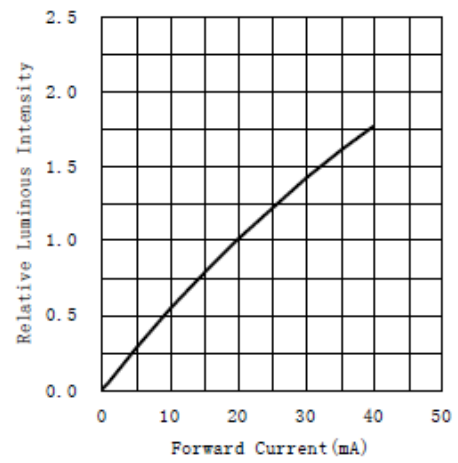

Forward Voltage VS. Forward Current

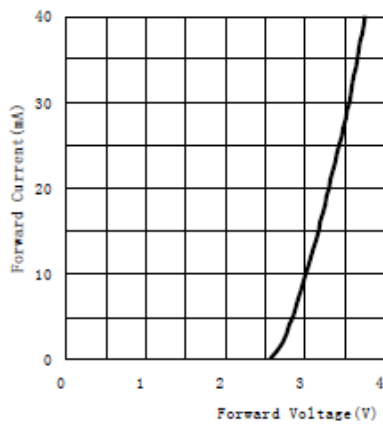

Ambient Temperature VS. Relative Intensity

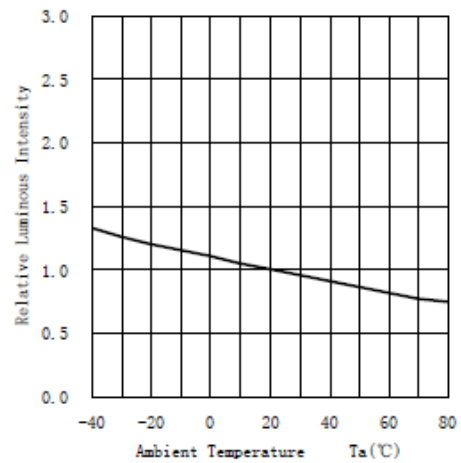

Relative spectral emission

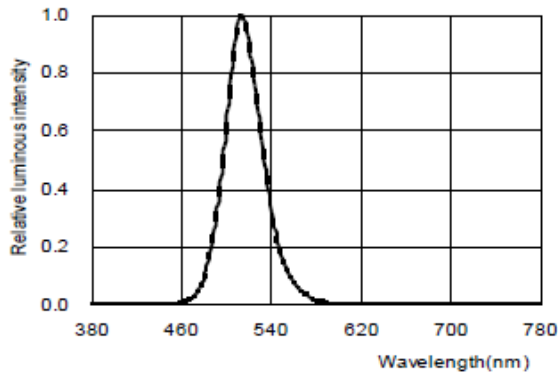

Radiation diagram

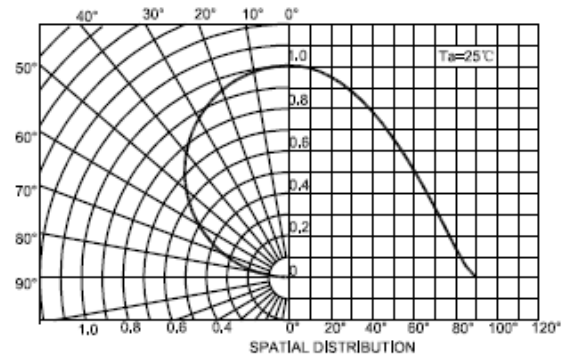

Tape reel

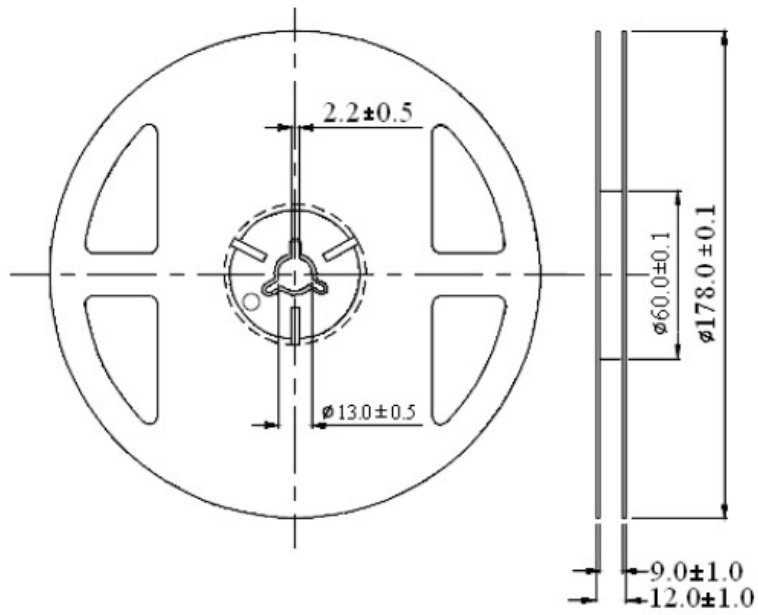

Unit: mm
Tolerance: ± 0.25 mm

Carrier Tape Dimensions:

Loaded quantity 2000PCS per reel.

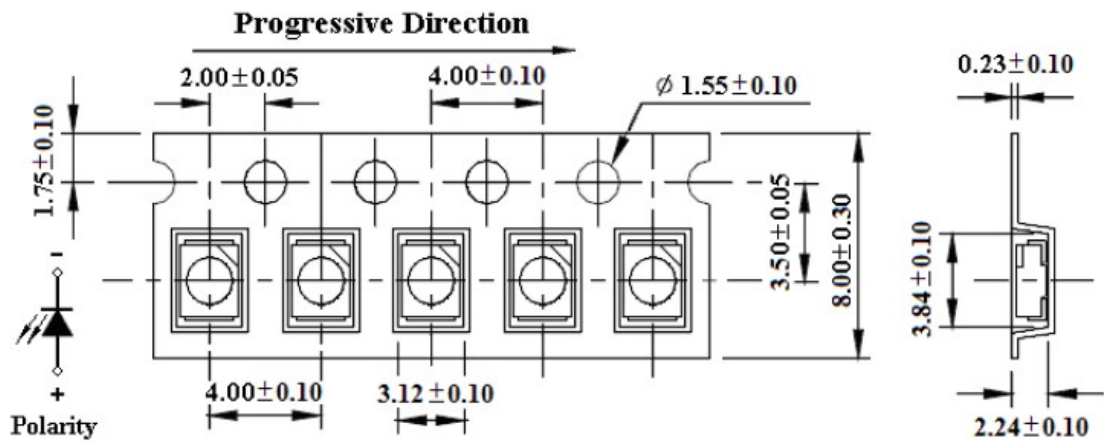

Unit: mm
Tolerance: ± 0.10 mm

Reflow soldering profile

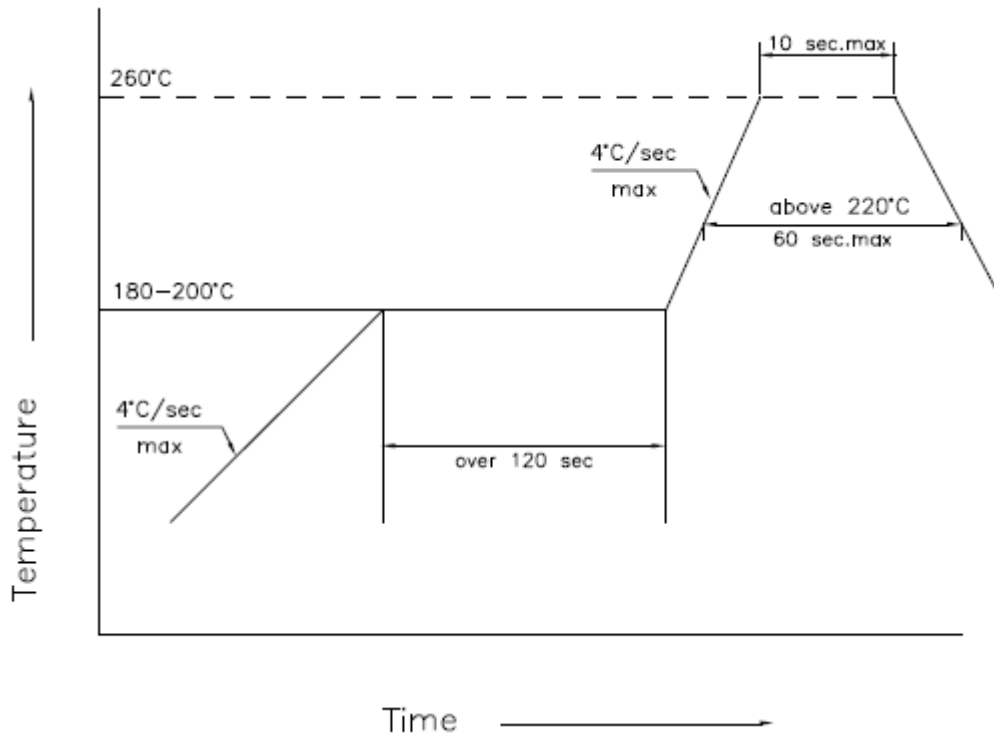

Storage

1. Do not open moisture proof bag before ready to use
2. Before opening the package, LEDs should be kept at 30°C or less and 80% RH or less.
3. After opening the package, LEDs should be kept at 30°C or less and 60% RH or less.
4. The LEDs should be used within one year.
5. The LEDs should be used within 72 hours after opening the package (MSL-Level 4)
6. If the silica gel bag has fabled away or storage time has exceeded, baking treatment should be performed. Conditions: 70±3°C for 24 hours.

Warranty

- (1) Perform an acceptance inspection on arrival of the goods. Return the defectives if any stipulating the disqualification and quantity.
- (2) Embedding the LEDs into the application and the verification of life and other qualities in practical use shall be executed by user.
- (3) Do not use the LEDs for the applications that require the higher reliability and security and that may endanger life and health by the breakdown and the malfunction. Seller shall not bear any responsibility or liability with respect to any claims and damages caused by user's usage of the LEDs without following our intended purpose or any written consent.
- (4) Seller shall not bear responsibility for any damages or defects caused by improper operation at the current in excess of the absolute maximum ratings that are not covered by warranty.